

Centerline Locators

Reference Spheres

Pins

3/8-24

M6 and 1/4-20

M5

M4

M3

M2

Contents

M5

Ruby Ball Styli, Carbide Shank

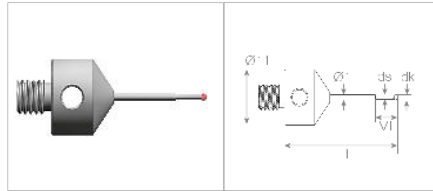

- ⊕ Ball: Ruby
- ⊕ Shank: Carbide, reduced
- ⊕ Ferrule: Conical
- ⊕ Ferrule: Stainless Steel

Order Number	dk	ds	L	ML	Wt.
STY-N0.2-21.8-11NTS	0.2	0.15	21.8	1.5	6.0
STY-N0.25-21.8-11NTS	0.25	0.2	21.8	2.5	6.0
STY-N0.3-21.8-11NTS	0.3	0.2	21.8	2.5	6.0
STY-N0.4-21.9-11NTS	0.4	0.3	21.9	2.5	6.0
STY-N0.5-22-11NTS	0.5	0.3	22.0	2.5	6.0
STY-N0.6-22.1-11NTS	0.6	0.4	22.1	4.5	6.0
STY-N0.7-22-2-11NTS	0.7	0.4	22.2	4.5	6.0
STY-N0.8-22.3-11NTS	0.8	0.6	22.3	4.5	6.0
STY-N0.9-22.4-11NTS	0.9	0.6	22.4	4.5	6.0
STY-N1.0-22.5-11NTS	1.0	0.8	22.5	4.5	6.0

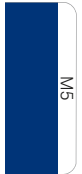

M5
Ruby Ball Styli
©2008 Paul W. Marino Gages, Inc.

Ruby Ball Styli, Carbide Shank

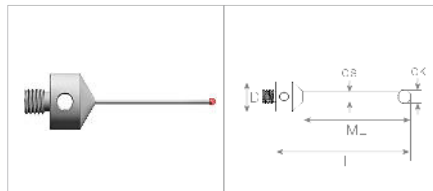

- ⊕ Ball: Ruby
- ⊕ Shank: Carbide
- ⊕ Ferrule: Conical
- ⊕ Ferrule: Stainless Steel

Order Number	dk	ds	L	ML	D	Wt.
STY-N1.35-32.9-11NTS	1.35	1.0	32.9	23.9	11.0	6.0
STY-N1.5-33-11NTS	1.5	1.0	33.0	24.0	11.0	6.0
STY-N2.0-33.5-11NTS	2.0	1.5	33.5	24.5	11.0	7.0
STY-N2.5-34-11NTS	2.5	1.5	34.0	25.0	11.0	7.0
STY-N3.0-34.5-18NTS	3.0	2.0	34.5	16.5	18.0	8.0
STY-N5.0-43.5-18NTS	5.0	3.5	43.5	25.5	18.0	11.0

SOLUTIONS®
"Be Creative"

"Specials are our specialty"®



Many styli and accessories are available with titanium ferrules by special order.

© 2008 Paul W. Marino Gages, Inc.

Ruby Ball Styli, Carbide Shank, M5

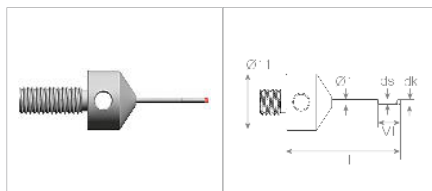

- ⊕ Ball: Ruby
- ⊕ Shank: Carbide, reduced
- ⊕ Ferrule: Stainless Steel, Conical
- ⊕ Extended thread for use with discs NTSG on page 107.

Order Number	dk	ds	L	ML	Wt.
STY-N0.2-21.8-11NTSL	0.2	0.15	21.8	1.5	6.0
STY-N0.25-21.8-11NTSL	0.25	0.2	21.8	2.5	6.0
STY-N0.3-21.8-11NTSL	0.3	0.2	21.8	2.5	6.0
STY-N0.4-21.9-11NTSL	0.4	0.3	21.9	2.5	6.0
STY-N0.5-22.0-11NTSL	0.5	0.3	22.0	2.5	6.0
STY-N0.6-22.1-11NTSL	0.6	0.4	22.1	4.5	6.0
STY-N0.7-22.2-11NTSL	0.7	0.4	22.2	4.5	6.0
STY-N0.8-22.3-11NTSL	0.8	0.6	22.3	4.5	6.0
STY-N0.9-22.4-11NTSL	0.9	0.6	22.4	4.5	6.0
STY-N1.0-22.5-11NTSL	1.0	0.8	22.5	4.5	6.0

Ruby Ball Styli, Carbide Shank

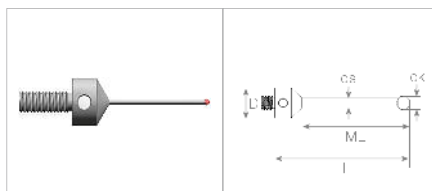

- ⊕ Ball: Ruby
- ⊕ Shank: Carbide
- ⊕ Ferrule: Stainless Steel, Conical
- ⊕ Extended thread for use with discs NTSG on page 107.

Order Number	dk	ds	L	ML	D	Wt.
STY-N1.35-32.9-11NTSL	1.35	1.0	32.9	23.9	11.0	6.0
STY-N1.5-33-11NTSL	1.5	1.0	33.0	24.0	11.0	6.0
STY-N2.0-33.5-11NTSL	2.0	1.5	33.5	24.5	11.0	7.0
STY-N2.5-34-11NTSL	2.5	1.5	34.0	25.0	11.0	7.0
STY-N3.0-34.5-18NTSL	3.0	2.0	34.5	16.5	18.0	8.0
STY-N5.0-43.5-18NTSL	5.0	3.5	43.5	25.5	18.0	11.0

SOLUTIONS® Use these tools to properly assemble your styli configurations. See more tools on pages 121-122.
 "How it works"



© 2008 Paul W. Marino Gages, Inc.

Phone (586) 759-2400
 www.pmargage.com

Fax: (586) 759-2423
 pwminc@covad.net

Ruby Ball Styli
 © 2006 Paul W. Marino Gages, Inc.

M5

Ruby Ball Styli, Carbide Shank

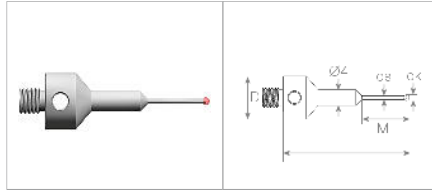

- ⊕ Ball: Ruby
- ⊕ Shank: Carbide, reduced
- ⊕ Ferrule: Conical
- ⊕ Ferrule: Stainless Steel

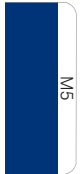

Ruby Ball Styli
 ©2008 Paul W. Marino Gages, Inc.

Order Number	dk	ds	L	ML	Wt.
STY-N0.2-32-11NTB	0.2	0.15	32.0	1.5	7.0
STY-N0.25-32-11NTB	0.25	0.2	32.0	2.5	7.0
STY-N0.3-32-11NTB	0.3	0.2	32.0	2.5	7.0
STY-N0.4-32-11NTB	0.4	0.3	32.0	2.5	7.0
STY-N0.5-32-11NTB	0.5	0.3	32.0	2.5	7.0
STY-N0.6-32-11NTB	0.6	0.4	32.0	4.5	7.0
STY-N0.7-32-11NTB	0.7	0.4	32.0	4.5	7.0
STY-N0.8-32-11NTB	0.8	0.6	32.0	12.0	7.0
STY-N0.9-32-11NTB	0.9	0.6	32.0	12.0	7.0
STY-N1.0-32-11NTB	1.0	0.8	32.0	12.0	7.0
STY-N1.35-32-11NTB	1.35	1.0	32.0	12.0	7.0
STY-N1.35-44-11NTB	1.35	1.0	44.0	19.0	7.0
STY-N1.5-32-11NTB	1.5	1.0	32.0	12.0	7.0
STY-N1.5-44-11NTB	1.5	1.0	44.0	19.0	7.0
STY-N2.0-32-11NTB	2.0	1.5	32.0	12.0	7.0
STY-N2.0-44-11NTB	2.0	1.5	44.0	19.0	8.0
STY-N2.0-58-11NTB	2.0	1.5	58.0	33.0	8.0
STY-N2.5-32-11NTB	2.5	1.5	32.0	12.0	7.0
STY-N2.5-44-11NTB	2.5	1.5	44.0	19.0	8.0
STY-N2.5-58-11NTB	2.5	1.5	58.0	33.0	8.0

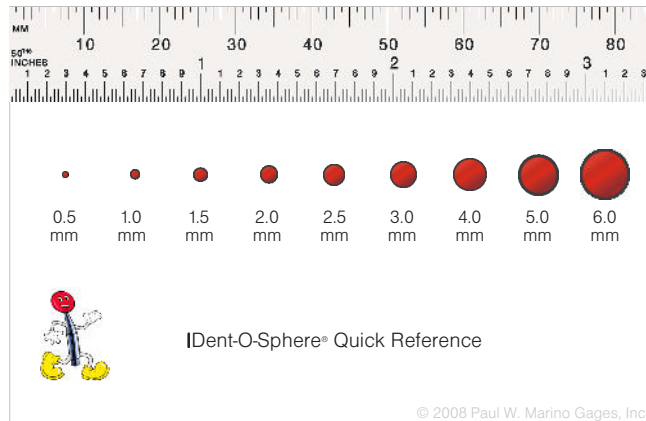

Ruby Ball Styli, Carbide Shank

M5

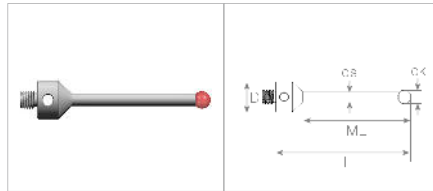

- ⊕ Ball: Ruby
- ⊕ Shank: Carbide,
- ⊕ Ferrule: Conical
- ⊕ Ferrule: Stainless Steel

Order Number	dk	ds	L	ML	D	Wt.
STY-N3.0-22-11NTB	3.0	2.0	22.0	12.0	11.0	6.0
STY-N3.0-25-11NTB	3.0	2.0	25.0	15.0	11.0	6.0
STY-N3.0-33.5-11NTB	3.0	2.0	33.5	23.5	11.0	6.0
STY-N3.0-50-11NTB	3.0	2.0	50.0	40.0	11.0	7.0
STY-N3.0-58-11NTB	3.0	2.0	58.0	48.0	11.0	8.0
STY-N4.0-33.5-11NTB	4.0	2.0	33.5	23.5	11.0	7.0
STY-N4.0-64-11NTB	4.0	2.0	64.0	54.0	11.0	8.0
STY-N5.0-50-11NTB	5.0	3.5	50.0	40.0	11.0	11.0
STY-N5.0-53-11NTB	5.0	3.5	53.0	43.0	11.0	12.0
STY-N5.0-75-11NTB	5.0	3.5	75.0	65.0	11.0	15.0
STY-N6.0-22-11NTB	6.0	3.5	22.0	12.0	11.0	12.0
STY-N6.0-54-11NTB	6.0	3.5	54.0	44.0	11.0	12.0
STY-N7.0-55-11NTB	7.0	3.5	55.0	45.0	11.0	13.0
STY-N8.0-63.5-11NTB	8.0	6.0	63.5	50.5	11.0	26.0
STY-N8.0-74-11NTB	8.0	6.0	74.0	61.0	11.0	32.0
STY-N8.0-75-11NTB	8.0	6.0	75.0	62.0	11.0	32.0
STY-N8.0-100-11NTB	8.0	6.0	100.0	87.0	11.0	42.0
STY-N8.0-114.5-11NTB	8.0	6.0	114.5	101.5	11.0	46.0
STY-N9.0-64.5-11NTB	9.0	6.0	64.5	51.5	11.0	27.0
STY-N10.0-65.5-11NTB	10.0	6.0	65.5	60.0	11.0	27.0
STY-N10.0-118-11NTB	10.0	6.0	118.0	105.0	11.0	49.0
STY-N8.0-63.5-18NTB	8.0	6.0	63.5	41.5	18.0	42.0
STY-N8.0-114.5-18NTB	8.0	6.0	114.5	92.5	18.0	63.0
STY-N9.0-64.5-18NTB	9.0	6.0	64.5	42.5	18.0	42.0
STY-N10.0-65.5-18NTB	10.0	6.0	65.5	43.5	18.0	43.0

M5
Ruby Ball Styli
© 2006 Paul W. Marino Gages, Inc.

SOLUTIONS®
"How it works"

Tighten gently and properly with the correct tools and extend the life of your components.

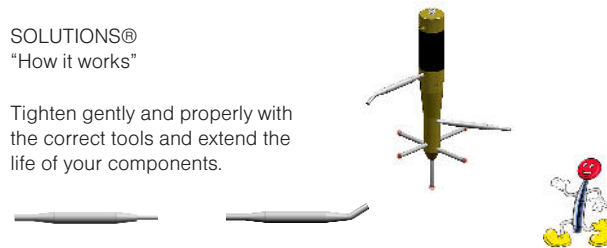

© 2008 Paul W. Marino Gages, Inc.

Phone (586) 759-2400
www.pmarginc.com

101

Fax: (586) 759-2423
pwminc@covad.net

M5

Ruby Ball Styli, Ceramic Shank

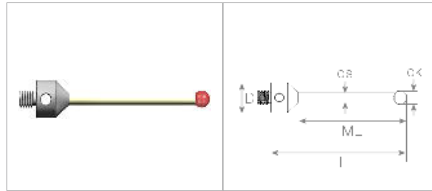

- ⊕ Ball: Ruby
- ⊕ Shank: Ceramic
- ⊕ Ferrule: Conical
- ⊕ Ferrule: Stainless Steel

Order Number	dk	ds	L	ML	D	Wt.
STY-N5.0-53-11NTKE	5.0	3.5	53.0	43.0	11.0	7.0
STY-N6.0-54-11NTKE	6.0	3.5	54.0	44.0	11.0	7.0
STY-N7.0-55-11NTKE	7.0	3.5	55.0	45.0	11.0	8.0
STY-N8.0-63.5-11NTKE	8.0	6.0	63.5	50.5	11.0	12.0
STY-N8.0-63.5-18NTKE	8.0	6.0	63.5	41.5	18.0	32.0
STY-N8.0-114.5-11NTKE	8.0	6.0	114.5	101.5	11.0	18.0
STY-N8.0-114.5-18NTKE	8.0	6.0	114.5	92.5	18.0	38.0
STY-N9.0-64.5-11NTKE	9.0	6.0	64.5	51.5	11.0	13.0
STY-N9.0-64.5-18NTKE	9.0	6.0	64.5	42.5	18.0	32.0
STY-N10.0-65.5-11NTKE	10.0	6.0	65.5	52.5	11.0	13.0
STY-N10.0-65.5-18NTKE	10.0	6.0	65.5	43.5	18.0	33.0

M5

Ruby Ball Styli
©2008 Paul W. Marino Gages, Inc.

SOLUTIONS®
"How it works"

Use these tools to properly assemble your styli configurations. See more on pages 121-122



© 2008 Paul W. Marino Gages, Inc.

Ruby Ball Styli, Carbon Shank

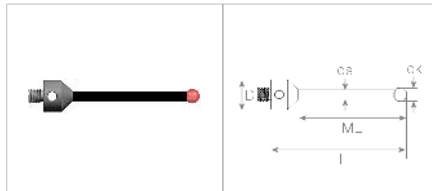

- ⊕ Ball: Ruby
- ⊕ Shank: Carbon Fiber
- ⊕ Ferrule: Conical
- ⊕ Ferrule: Stainless Steel

Order Number	dk	ds	L	ML	D	Wt.
STY-N4.0-33.5-11NTCA	4.0	3.0	33.5	23.5	11.0	5.0
STY-N5.0-53-11NTCA	5.0	3.5	53.0	43.0	11.0	6.0
STY-N6.0-54-11NTCA	6.0	3.5	54.0	44.0	11.0	6.0

Continued on next page

Ruby Ball Styli, Carbon Shank

M5

Continued from previous page

Order Number	dk	ds	L	ML	D	Wt.
STY-N7.0-55-11NTCA	7.0	3.5	55.0	45.0	11.0	7.0
STY-N8.0-63.5-11NTCA	8.0	6.0	63.5	50.5	11.0	8.0
STY-N8.0-63.5-18NTCA	8.0	6.0	63.5	41.5	18.0	29.0
STY-N8.0-114.5-11NTCA	8.0	6.0	114.5	101.5	11.0	11.0
STY-N8.0-114.5-18NTCA	8.0	6.0	114.5	92.5	18.0	92.5
STY-N8.0-200-11NTCA	8.0	6.0	200.0	187.0	11.0	13.0
STY-N9.0-64.5-11NTCA	9.0	6.0	64.5	51.5	11.0	9.0
STY-N9.0-64.5-18NTCA	9.0	6.0	64.5	42.5	18.0	29.0
STY-N10.0-65.5-11NTCA	10.0	6.0	65.5	52.5	11.0	9.0
STY-N10.0-65.5-18NTCA	10.0	6.0	65.5	43.5	18.0	30.0

SOLUTIONS®
"Be Creative"

Pre-make assemblies for your most common parts and keep them on hand for quick access.

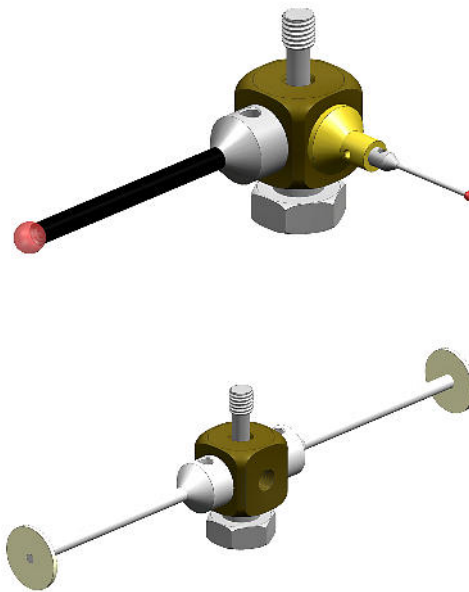

Buy online at www.shoppwm.com



© 2008 Paul W. Marino Gages, Inc.

M5
Ruby Ball Styli

© 2006 Paul W. Marino Gages, Inc.

M5 Ruby Ball Styli, Ceramic Shank, Light Weight

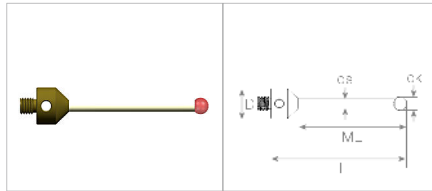

- ⊕ Ball: Ruby
- ⊕ Shank: Ceramic
- ⊕ Ferrule: Conical
- ⊕ Ferrule: Alu 7075
- ⊕ Reduced weight

Order Number	dk	ds	L	ML	D	Wt.
STY-N5.0-53-11NTKP	5.0	3.5	53.0	43.0	11.0	4.0
STY-N6.0-54-11NTKP	6.0	3.5	54.0	44.0	11.0	4.0
STY-N7.0-55-11NTKP	7.0	3.5	55.0	45.0	11.0	5.0
STY-N8.0-63.5-11NTKP	8.0	6.0	63.5	50.5	11.0	9.0
STY-N8.0-63.5-18NTKP	8.0	6.0	63.5	41.5	18.0	15.0
STY-N8.0-114.5-11NTKP	8.0	6.0	114.5	101.5	11.0	15.0
STY-N8.0-114.5-18NTKP	8.0	6.0	114.5	92.5	18.0	21.0
STY-N9.0-64.5-11NTKP	9.0	6.0	64.5	51.5	11.0	10.0
STY-N9.0-64.5-18NTKP	9.0	6.0	64.5	42.5	18.0	15.0
STY-N10.0-65.5-11NTKP	10.0	6.0	65.5	52.5	11.0	10.0
STY-N10.0-65.5-18NTKP	10.0	6.0	65.5	43.5	18.0	16.0



Ruby Ball Styli
 ©2008 Paul W. Marino Gages, Inc.

SOLUTIONS®
"How it works"

Lightweight ceramic and carbon fiber styli save even more weight because of their aluminum ferrules. Comparison of 5.0 mm ruby x 53.0 mm shank, M5 thread

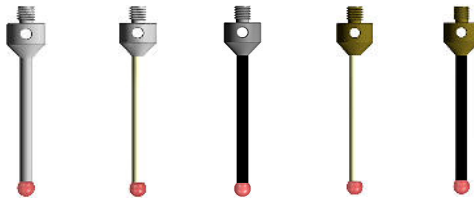

Shank / Ferrule	Carbide / SST	Ceramic / SST	Carbon / SST	Ceramic / Aluminum	Carbon / Aluminum
Weight	12.0g	7.0g	6.0g	4.0g	3.0g



Most styli are also available with titanium ferrules by special order.

© 2008 Paul W. Marino Gages, Inc.

Ruby Ball Styli, Carbon Shank, Light Weight M5

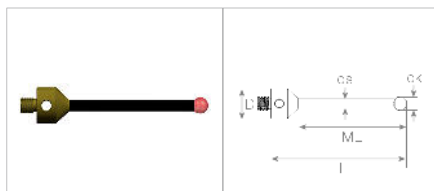

- ⊕ Ball: Ruby
- ⊕ Shank: Carbon Fiber
- ⊕ Ferrule: Conical
- ⊕ Ferrule: Alu 7075
- ⊕ Reduced weight

Order Number	dk	ds	L	ML	D	Wt.
STY-N4.0-33.5-11NTCP	4.0	3.0	33.5	23.5	11.0	2.0
STY-N5.0-53-11NTCP	5.0	3.5	53.0	43.0	11.0	3.0
STY-N6.0-54-11NTCP	6.0	3.5	54.0	44.0	11.0	3.0
STY-N7.0-55-11NTCP	7.0	3.5	55.0	45.0	11.0	4.0
STY-N8.0-63.5-11NTCP	8.0	6.0	63.5	50.5	11.0	5.0
STY-N8.0-63.5-18NTCP	8.0	6.0	63.5	41.5	18.0	12.0
STY-N8.0-114.5-11NTCP	8.0	6.0	114.5	101.5	11.0	8.0
STY-N8.0-114.5-18NTCP	8.0	6.0	114.5	92.5	18.0	14.0
STY-N9.0-64.5-11NTCP	9.0	6.0	64.5	51.5	11.0	6.0
STY-N9.0-64.5-18NTCP	9.0	6.0	64.5	42.5	18.0	12.0
STY-N10.0-65.5-11NTCP	10.0	6.0	65.5	52.5	11.0	6.0
STY-N10.0-65.5-18NTCP	10.0	6.0	65.5	43.5	18.0	13.0

M5

Precision Probe Ruby Ball / Carbide Shank

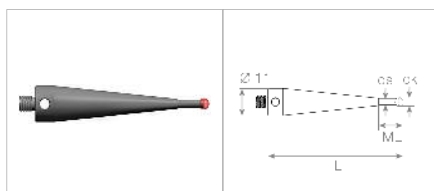

- ⊕ Ball: Ruby
- ⊕ Shank: Carbide
- ⊕ Ferrule: Conical
- ⊕ Ferrule: Stainless Steel

Order Number	dk	ds	L	ML	Wt.
STY-N1.0-55-11NTF	1.0	0.8	55.0	4.0	17.0
STY-N1.5-55-11NTF	1.5	1.0	55.0	5.0	17.0
STY-N2.0-55-11NTF	2.0	1.5	55.0	5.0	18.0
STY-N2.5-55-11NTF	2.5	1.5	55.0	5.0	18.0
STY-N3.5-55-11NTF	3.5	2.0	55.0	10.0	18.0

Ruby Ball Styli
© 2006 Paul W. Marmo Gages, Inc.

M5

Disc Styli, Ceramic

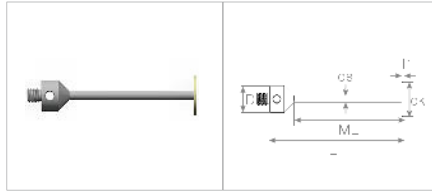

- ⊕ Disc: Ceramic
- ⊕ Shank: Carbide
- ⊕ Ferrule: Conical
- ⊕ Ferrule: Stainless Steel
- ⊕ Non-magnetic disc

Order Number	dk	H1	L	ds	D	Wt.
STY-N5.0-45-11NKS	5.0	0.5	45.0	2.0	11.0	7.0
STY-N10.0-55-11NKS	10.0	0.8	55.0	3.0	11.0	11.0
STY-N14.0-55-11NKS	14.0	1.0	55.0	3.0	11.0	11.0

SOLUTIONS®
"How it works"

Select disc styli for notches and grooves. Add a lightweight extension, a knuckle, or both, for difficult to access bores.

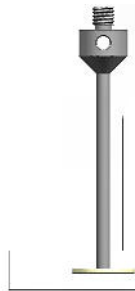

© 2008 Paul W. Marino Gages, Inc.

M5
 Disc Styli
 ©2008 Paul W. Marino Gages, Inc.

Disc Styli, Ceramic

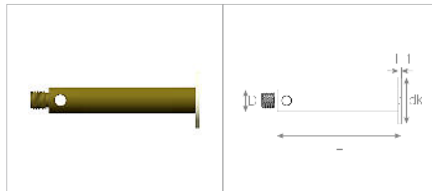

- ⊕ Disc: Ceramic
- ⊕ Shank: Alu 7075
- ⊕ Non-magnetic disc

Order Number	dk	H1	L	D	Wt.
STY-N15-40NKS	15.0	1.0	40.0	7.0	5.0
STY-N20-60NKS	20.0	1.0	60.0	7.0	8.0

Disc Styli, Steel

M5

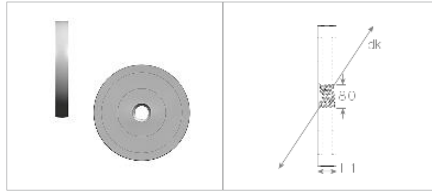

- ⊕ Disc: Stainless Steel
- ⊕ Features M5 center hole
- ⊕ For use with extended thread probes or NSL screws

Order Number	dk	H1	Wt.
STY-N10-4NTSG	10.0	4.0	2.0
STY-N15-4NTSG	15.0	4.0	5.0
STY-N20-4NTSG	20.0	4.0	11.0
STY-N30-4NTSG	30.0	4.0	22.0
STY-N40-4NTSG	40.0	4.0	33.0
STY-N50-5NTSG	50.0	5.0	65.0
STY-N60-6NTSG	60.0	6.0	115.0

Disc Styli, Steel

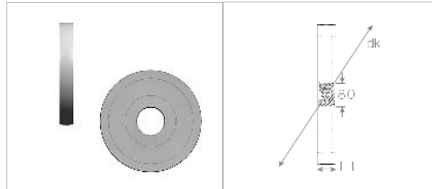

- ⊕ Disc: Stainless Steel
- ⊕ Features 8.0 mm diameter center hole
- ⊕ For use with NST screws

Order Number	dk	H1	Wt.
STY-N15-4NTSA	15.0	4.0	4.0
STY-N20-2NTSA	20.0	2.0	4.0
STY-N20-4NTSA	20.0	4.0	8.0
STY-N30-4NTSA	30.0	4.0	21.0
STY-N40-4NTSA	40.0	4.0	32.0
STY-N50-5NTSA	50.0	5.0	64.0
STY-N60-6NTSA	60.0	6.0	112.0

M5

Disc Styli
© 2006 Paul W. Marino Gages, Inc.

SOLUTIONS®
"How it works"

Make your own disc styli with standard extensions, discs and screws on pages 122-123.



© 2006 Paul W. Marino Gages, Inc.

Phone (586) 759-2400
www.pmargage.com

107

Fax: (586) 759-2423
pwminc@covad.net

M5

Star Styli, Ruby / Carbide

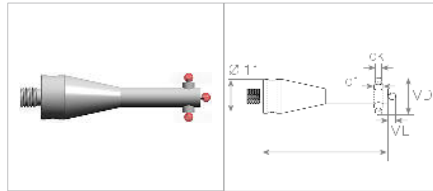

- ⊕ Ball: Ruby
- ⊕ Shank: Carbide
- ⊕ Ferrule: Conical
- ⊕ Ferrule: Stainless Steel

Order Number	dk	L	ML	MD	ds	Wt.
STY-N0.5-40-11NSTG	0.5	40.0	1.9	3.5	0.4	7.0
STY-N0.8-40-11NSTG	0.8	40.0	1.9	5.0	0.6	7.0
STY-N1.35-40-11NSTG	1.35	40.0	2.0	9.0	1.0	11.0
STY-N1.8-40-11NSTG	1.8	40.0	2.0	10.0	1.5	12.0
STY-N2.3-40-11NSTG	2.3	40.0	2.5	12.0	1.8	13.0

Star Styli, Ruby / Carbide

M5
Star Styli
©2008 Paul W. Marino Gages, Inc.

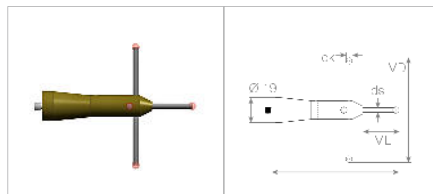

- ⊕ Ball: Ruby
- ⊕ Shank: Carbide
- ⊕ Ferrule: Conical
- ⊕ Body: Alu 7075

Order Number	dk	L	ML	MD	ds	Wt.
STY-N5.0-80-19NST	5.0	98.0	28.0	80.0	3.5	65.0

SOLUTIONS® "How it works"

PWM star styli are available in diverse designs with fixed arms, or create your own custom design with a cube adapter (see next page) and any combination of styli, extensions, knuckles or crossover adapters.

"Be creative"

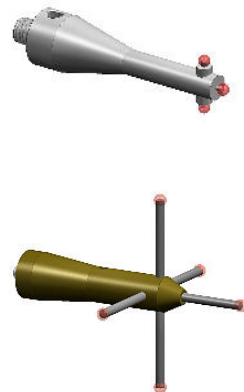

© 2008 Paul W. Marino Gages, Inc.

Star Cubes, Ruby / Alu 7075

M5

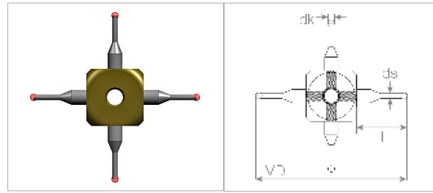

- ⊕ Ball: Ruby
- ⊕ Cube: Alu 7075
- ⊕ Arms can be replaced with styli below.
- ⊕ Replacement cubes are on page 114.

Order Number	dk	L	MD	ds	Wt.
STY-N1.0-45NWST	1.0	15.0	45.0	0.7	10.0
STY-N1.5-45NWST	1.5	15.0	45.0	1.1	10.0
STY-N2.0-45NWST	2.0	15.0	45.0	1.5	11.0
STY-N2.5-45NWST	2.5	15.0	45.0	1.8	11.0
STY-N3.5-45NWST	3.5	15.0	45.0	2.2	12.0

Replacement Arms for Star Cubes

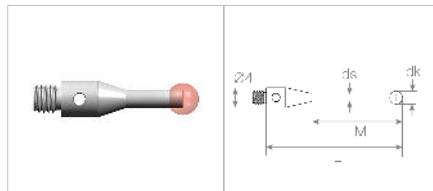

- ⊕ Ball: Ruby
- ⊕ Shank: Stainless Steel
- ⊕ Replacement arms for cubes shown above.

Order Number	dk	L	ML	ds	Wt.
STY-N1.0-15-3NTC	1.0	15.0	7.5	0.7	1.0
STY-N1.5-15-3NTC	1.5	15.0	—	1.1	1.0
STY-N2.0-15-3NTC	2.0	15.0	—	1.5	1.0
STY-N2.5-15-3NTC	2.5	15.0	—	1.8	1.0
STY-N3.5-15-3NTC	3.5	15.0	—	2.2	1.0

M5
Star Styli
© 2006 Paul W. Marino Gages, Inc.

SOLUTIONS®
"How it works"

Build lightweight stars and special configurations with cubes, styli, extensions and accessories of all types.

Think Modular

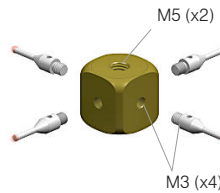

© 2006 Paul W. Marino Gages, Inc.

M5

Pointed Styli, Carbide

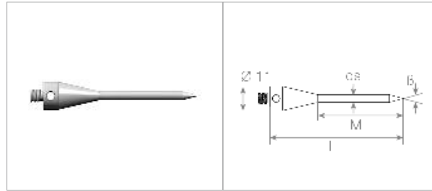

- ⊕ Tip: Carbide
- ⊕ Shank: Carbide
- ⊕ Ferrule: Stainless Steel

Order Number	β	L	ML	ds	Wt.
STY-N30-61-11NTS	30°	61.0	39.0	3.5	12.0

Cylinder Styli, Ruby / Stainless Steel

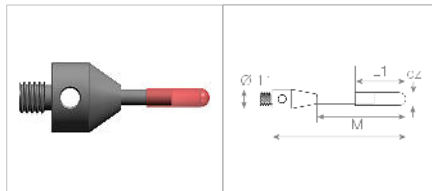

- ⊕ Cylinder: Ruby
- ⊕ Shank: Stainless Steel
- ⊕ Ferrule: Stainless Steel

Order Number	dz	L	ML	L1	Wt.
STY-N2.0-25-11NZRA	2.0	25.0	14.0	5.0	6.0
STY-N3.0-25-11NZRA	3.0	25.0	14.0	10.0	6.0
STY-N4.0-30-11NZRA	4.0	30.0	21.0	10.0	7.0

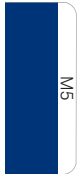

Point, Cylinder and Half Sphere Styli
©2006 Paul W. Marino Gages, Inc.

Hollow Ceramic Ball Styli

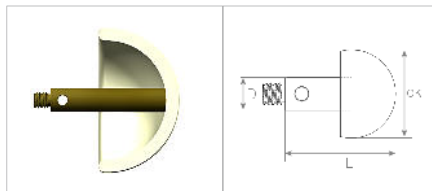

- ⊕ Ball: Ceramic, Hollow
- ⊕ Shank: Alu 7075

Order Number	dk	L	D	Wt.
STY-N18.0-16-11NHKE	18.0	16.0	11.0	8.0
STY-N24.0-19-11NHKE	24.0	19.0	11.0	11.0
STY-N30.0-22-11NHKE	30.0	22.0	11.0	14.0

Buy online at www.shoppwm.com

Extensions, Aluminum, Solid

M5

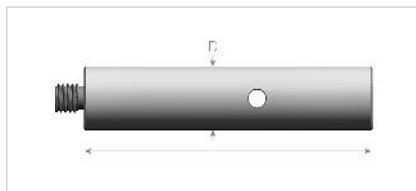

- ⊕ Shank: Aluminum
- ⊕ Threads: Stainless Steel
- ⊕ Solid body

Order Number	D	L	Wt.
STY-N25-11NVAL	11.0	25.0	6.0
STY-N40-11NVAL	11.0	40.0	10.0
STY-N50-11NVAL	11.0	50.0	13.0
STY-N60-11NVAL	11.0	60.0	15.0
STY-N80-11NVAL	11.0	80.0	20.0
STY-N100-11NVAL	11.0	100.0	25.0
STY-N120-11NVAL	11.0	120.0	30.0

Extensions, Aluminum 7075, Solid

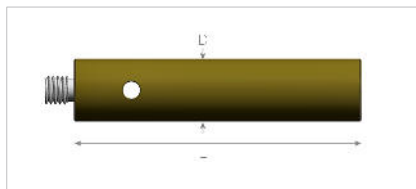

- ⊕ Shank: Alu 7075
- ⊕ Threads: Stainless Steel
- ⊕ Solid body

Order Number	D	L	Wt.
STY-N10-11NVPE	11.0	10.0	2.0
STY-N15-11NVPE	11.0	15.0	3.0
STY-N20-11NVPE	11.0	20.0	5.0
STY-N25-11NVPE	11.0	25.0	6.0
STY-N40-11NVPE	11.0	40.0	10.0
STY-N50-11NVPE	11.0	50.0	13.0
STY-N15-18NVPE	18.0	15.0	10.0
STY-N25-18NVPE	18.0	25.0	17.0
STY-N40-18NVPE	18.0	40.0	28.0
STY-N50-18NVPE	18.0	50.0	35.0

M5
Extensions
© 2006 Paul W. Marmo Gages, Inc.

SOLUTIONS®
"Be Creative"

Titanium extensions and accessories
are available by special order.



M5 Extensions, Aluminum 7075, Hollow

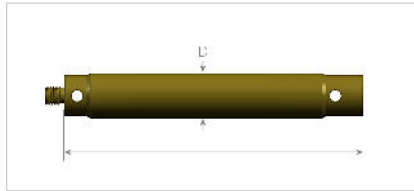

- ⊕ Shank: Alu 7075
- ⊕ Threads: Aluminum
- ⊕ Hollow body

Order Number	D	L	Wt.
STY-N60-11NVPE	11.0	60.0	11.0
STY-N60-18NVPE	18.0	60.0	31.0
STY-N75-11NVPE	11.0	75.0	12.0
STY-N75-18NVPE	18.0	75.0	36.0
STY-N80-11NVPE	11.0	80.0	13.0
STY-N80-18NVPE	18.0	80.0	37.0
STY-N90-11NVPE	11.0	90.0	14.0
STY-N90-18NVPE	18.0	90.0	40.0
STY-N100-11NVPE	11.0	100.0	15.0
STY-N100-18NVPE	18.0	100.0	42.0
STY-N120-11NVPE	11.0	120.0	16.0
STY-N120-18NVPE	18.0	120.0	49.0
STY-N150-11NVPE	11.0	150.0	19.0
STY-N150-18NVPE	18.0	150.0	58.0
STY-N200-18NVPE	18.0	200.0	73.0
STY-N250-18NVPE	18.0	250.0	89.0
STY-N300-18NVPE	18.0	300.0	103.0

M5
 Extensions
 ©2008 Paul W. Marino Gages, Inc.

SOLUTIONS®
 "How it works"

Tighten gently and properly with a set of tools and extend the life of your components.

See more tools on pages 121-122

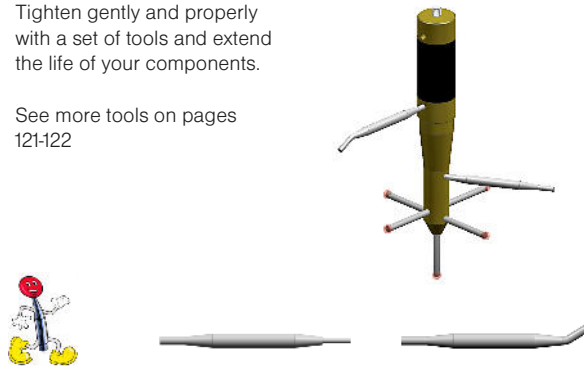

© 2008 Paul W. Marino Gages, Inc.

Extensions, Carbon Fiber, Hollow

M5

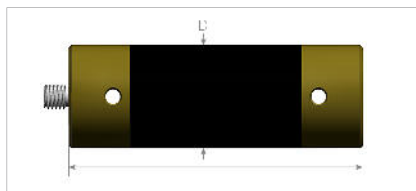

- ⊕ Shank: Carbon Fiber
- ⊕ Threads: Stainless Steel
- ⊕ Hollow body

Order Number	D	L	Wt.
STY-N40-11NVCA	11.0	40.0	6.8
STY-N50-11NVCA	11.0	50.0	8.4
STY-N50-18NVCA	18.0	50.0	23.0
STY-N60-11NVCA	11.0	60.0	9.0
STY-N60-18NVCA	18.0	60.0	24.0
STY-N75-11NVCA	11.0	75.0	10.0
STY-N80-11NVCA	11.0	80.0	10.0
STY-N80-18NVCA	18.0	80.0	27.0
STY-N90-11NVCA	11.0	90.0	10.0
STY-N100-11NVCA	11.0	100.0	11.0
STY-N100-18NVCA	18.0	100.0	30.0
STY-N120-11NVCA	11.0	120.0	12.0
STY-N120-18NVCA	18.0	120.0	33.0
STY-N150-11NVCA	11.0	150.0	13.0
STY-N150-18NVCA	18.0	150.0	36.0
STY-N160-11NVCA	11.0	160.0	14.0
STY-N200-11NVCA	11.0	200.0	16.0
STY-N200-18NVCA	18.0	200.0	43.0
STY-N210-11NVCA	11.0	210.0	17.0
STY-N250-11NVCA	11.0	250.0	19.0
STY-N250-18NVCA	18.0	250.0	50.0
STY-N300-11NVCA	11.0	300.0	22.0
STY-N300-18NVCA	18.0	300.0	57.0
STY-N400-18NVCA	18.0	400.0	72.0
STY-N500-18NVCA	18.0	500.0	87.0

M5
Extensions
© 2006 Paul W. Marino Gages, Inc.

SOLUTIONS®
"How it works"

Extensions are also available in titanium. Contact us for details.



© 2008 Paul W. Marino Gages, Inc.

M5

Cubes, Aluminum 7075

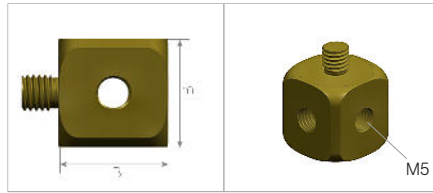

- ⊕ Cube: Aluminum 7075
- ⊕ Threads: Stainless Steel
- ⊕ Threads: One M5 Male, Five M5 female

Order Number	B	Wt.	Use with screw
STY-N15-15NWA	15.0	8.0	N5-20NSWA
STY-N20-20NWA	20.0	20.0	N5-25NSWA

Cubes, Aluminum 7075

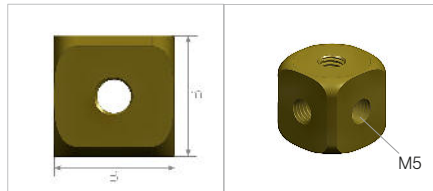
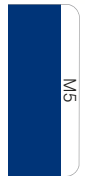

- ⊕ Cube: Aluminum 7075
- ⊕ Threads: Stainless Steel
- ⊕ Threads: Six M5 female
- ⊕ Use with screws

Order Number	B	Wt.	Use with screw
STY-N15-15NWB	15.0	7.0	N5-20NSWA / B
STY-N20-20NWB	20.0	20.0	N5-25NSWA / B

Cubes
©2008 Paul W. Marino Gages, Inc.

Cubes, Aluminum 7075

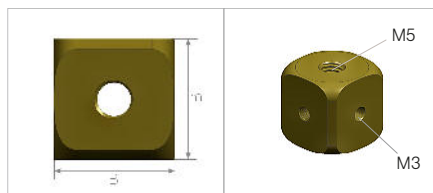

- ⊕ Cube: Aluminum 7075
- ⊕ Threads: Stainless Steel
- ⊕ Threads: Four M3 female, two M5 female

Order Number	B	Wt.	Use with screw
STY-N15-15NWST	15.0	8.0	N5-20NWSA / B
STY-N20-20NWST	20.0	20.0	N5-25NWSA / B



Combine with screws on pages 122-123 and make offset arms by rotating the cube.

Cubes are also available in titanium.

© 2008 Paul W. Marino Gages, Inc.

Cube, Double, Aluminum 7075

M5

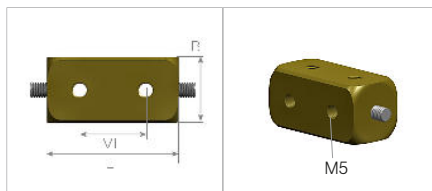

- ⊕ Cube: Aluminum 7075
- ⊕ Threads: Stainless Steel
- ⊕ Threads: Eight M5 female threads for use with any M5 component

Order Number	B	L	ML	Wt.
STY-N20-20NDW	20.0	40.0	20.0	40.0

Cube, Extension, Aluminum 7075

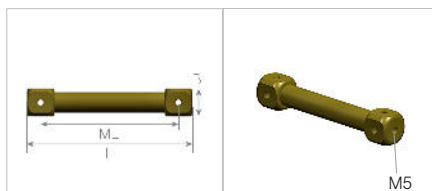

- ⊕ Cube: Aluminum 7075
- ⊕ Threads: Stainless Steel
- ⊕ Threads: Eight M5 female

Order Number	B	L	ML	Wt.
STY-N20-20NWV	20.0	120.0	100.0	55.0

Multi-Cube, Aluminum 7075

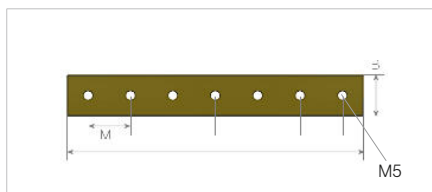

- ⊕ Cube: Aluminum 7075
- ⊕ Threads: Stainless Steel
- ⊕ Threads: M5 female

Order Number	B	L	ML	Wt.
STY-N20-20NMW	20.0	140.0	20.0	144.0

SOLUTIONS® "How it works"

Make your own star configurations by combining styli, extensions and adapters — think modular.

Most cubes are also available in titanium. Contact us for details.



© 2008 Paul W. Marino Gages, Inc.

Cubes M5
© 2006 Paul W. Marino Gages, Inc.

M5

Swivel Styli, Ruby Ball / Carbide

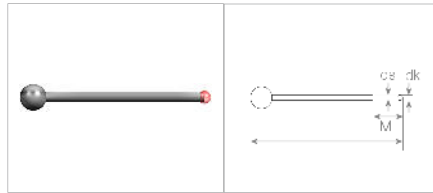

- ⊕ Ball: Ruby
- ⊕ Shank: Carbide
- ⊕ For use with Type NHTS holder shown below

Order Number	dk	ds	L	ML	Wt.
STY-N1.0-17.5NTES	1.0	0.8	17.5	5.0	1.0

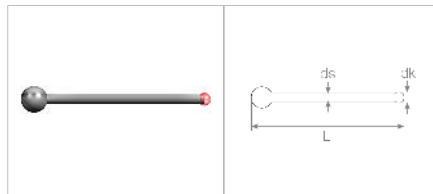

- ⊕ Ball: Ruby
- ⊕ Shank: Carbide
- ⊕ For use with Type NHTS holder shown below

Order Number	dk	ds	L	ML	Wt.
STY-N2.0-28.5NTES	2.0	1.5	28.5	—	1.0

M5

Swivel Styli and Holder
©2008 Paul W. Marino Gages, Inc.

Holder for Pin Styli (Type NTES)

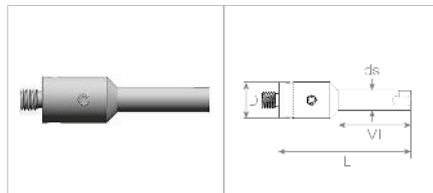

- ⊕ Shank: Stainless Steel
- ⊕ For use with Type NTES swivel styli shown above.
- ⊕ Roll, pivot and lock in place

Order Number	D	ds	L	ML	Wt.
STY-N1.0-40-11NHTS	11.0	6.0	40.0	22.0	15.0

SOLUTIONS®
"How it works"

NHTS holders allow swivel styli, Type NTES, to rotate 360° at any angle up to 110°.

© 2008 Paul W. Marino Gages, Inc.

Adapters, Crossover, SST

M5

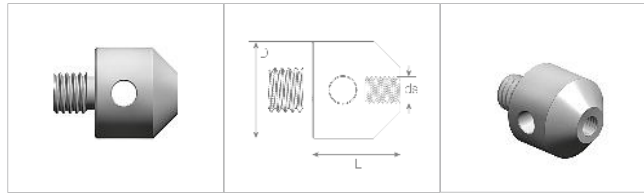

- ⊕ Shank: Stainless Steel
- ⊕ Convert any M2, M3 or M4 stylus or accessory for use on an M5 system.

Order Number	ds	L	D	Wt.
STY-N5-2NAZ	M2	10.0	11.0	5.7
STY-N5-3NAZ	M3	10.0	11.0	5.7
STY-N5-4NAZ	M4	10.0	11.0	5.7

Adapters, Crossover, SST

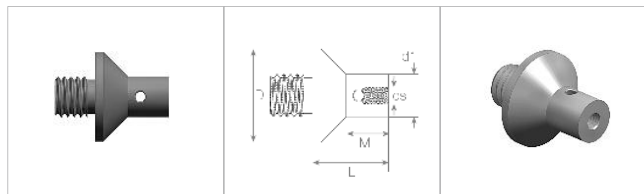

- ⊕ Shank: Stainless Steel
- ⊕ Convert any M2, M3 or M4 stylus or accessory for use on an M5 system.

Order Number	ds	L	ML	d1	D	Wt.
STY-NAZ11-2	M2	9.0	5.0	5.0	11.0	3.1
STY-NAL12-2	M2	9.0	5.0	5.0	12.0	3.1
STY-NAZ11-3	M3	11.0	7.0	5.0	11.0	3.2
STY-NAL12-3	M3	11.0	7.0	5.0	12.0	3.2
STY-NAZ11-4	M4	11.0	7.0	5.0	11.0	3.2
STY-NAL12-4	M4	11.0	7.0	5.0	12.0	3.2

M5
Adapters, Crossover
© 2006 Paul W. Marino Gages, Inc.

SOLUTIONS®
"How it works"

Crossover adapters convert styli for use on systems designed for other threads. Not sure which to use? Contact us for help building a custom configuration from standard components.

M5 to M2
Adapter



M2
Stylus



© 2008 Paul W. Marino Gages, Inc.

Phone (586) 759-2400
www.pmargage.com

117

Fax: (586) 759-2423
pwminc@covad.net

M5

Adapters, Crossover, Gold Series

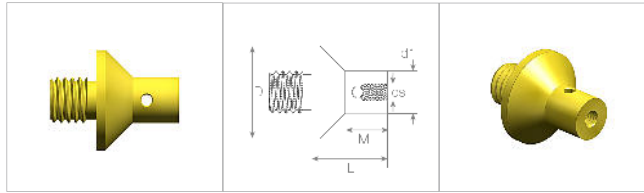

- ⊕ Shank: Alu 7075
- ⊕ Convert any M2, M3 or M4 stylus or accessory for use on an M5 system.

Order Number	ds	L	ML	d1	D	Wt.
STY-NAZ11-2P	M2	9.0	5.0	5.0	11.0	3.1
STY-NAZ11-3P	M3	11.0	7.0	5.0	11.0	3.2
STY-NAZ11-4P	M4	11.0	7.0	5.0	11.0	3.2

M5
 Adapters, Crossover
 ©2006 Paul W. Marino Gages, Inc.

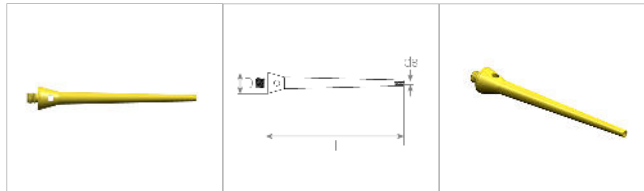

- ⊕ Shank: Alu 7075
- ⊕ Convert any M2, M3 or M4 stylus or accessory for use on an M5 system.
- ⊕ Extended length provides greater access to tight spaces

Order Number	ds	L	D	Wt.
STY-PAM5-M2STR-A	M2	74.0	11.0	—
STY-PAM5-M3STR-A	M3	74.0	11.0	—
STY-PAM5-M4STR-A	M4	74.0	11.0	—

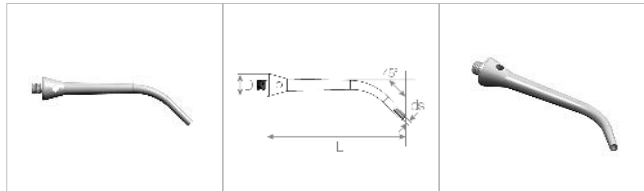

- ⊕ Shank: Stainless Steel
- ⊕ Convert any M2, M3 or M4 stylus or accessory for use on an M5 system.
- ⊕ Also available in 90° angle design

Order Number	ds	L	D	Wt.
STY-PAM5-M2ANG-45SST	M2	69.0	11.0	—
STY-PAM5-M3ANG-45SST	M3	69.0	11.0	—
STY-PAM5-M4ANG-45SST	M4	69.0	11.0	—

Adapters, Knuckle

M5

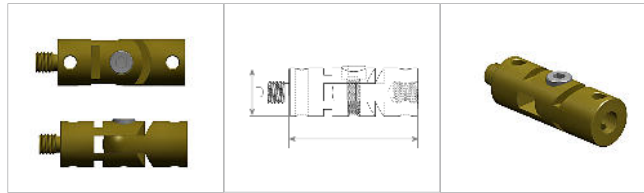

- ⊕ Knuckle
- ⊕ Alu 7075
- ⊕ M5 male and M5 female threads
- ⊕ Basic hex wrench included

Order Number	L	D	Wt.
STY-N30-11NGA	30.0	11.0	7.0
STY-N36-18NGA	36.0	11.0	24.0

SOLUTIONS®
"How it works"

Use adapters or knuckles to measure hard to reach places. Many adapters are also available in titanium.

See tools on pages 121–122.

© 2008 Paul W. Marino Gages, Inc.

M5
Adapters, Knuckle
© 2008 Paul W. Marino Gages, Inc.

Adapters, Knuckle, Rotary

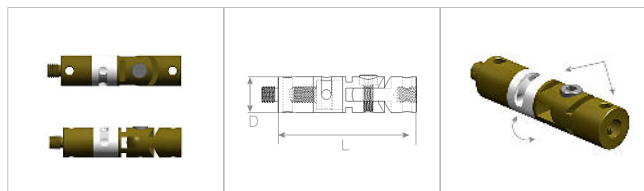

- ⊕ Knuckle, rotary
- ⊕ Alu 7075
- ⊕ M5 male and M5 female threads
- ⊕ Basic hex wrench included

Order Number	L	D	Wt.
STY-N43-11NGD	43.0	11.0	13.0
STY-N55-18NDG	55.0	18.0	38.0

M5

Adapters, Rotary

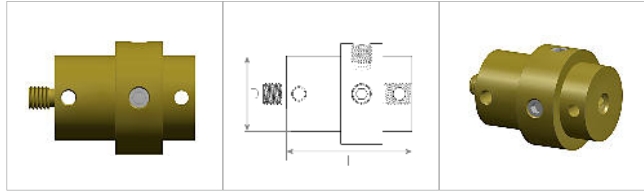

- ⊕ Threads: M5
- ⊕ Body: Alu 7075
- ⊕ Body: Rotate and lock

Order Number	L	D	Wt.
STY-N30-18NDS	30.0	18.0	28.0

Adapters, Rotary with Piezo

M5

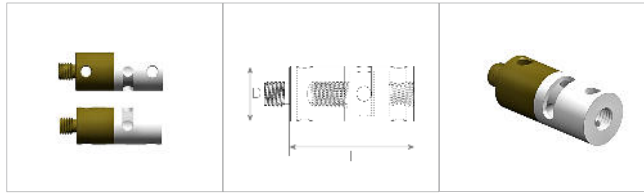

Adapters, Rotary
©2008 Paul W. Marino Gages, Inc.

- ⊕ Threads: M5
- ⊕ Body: Alu 7075
- ⊕ Body: Rotate and lock

Order Number	L	D	Wt.
STY-N25-11NDSP	25.0	11.0	9.0
STY-N25-18NDSP	25.0	18.0	21.0

SOLUTIONS® "How it works"

Piezo—from the Greek, meaning "to press or squeeze"

Mechanical compliance, which is the inverse of spring constant, is a function of the shape, modulus and type of load.

Example: Simple beam—Uniform load.

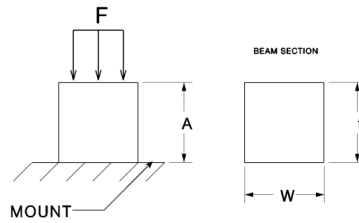

$$C_w = \frac{A}{AY} = \frac{A}{Wt}$$

$$L_w = \rho A W t$$

C_w = MECHANICAL COMPLIANCE
 L_w = MASS



© 2008 Paul W. Marino Gages, Inc.

Tools

M5



- ⊕ Pin key, single
- ⊕ Material: Steel
- ⊕ Straight pin

Order Number	ds	d1	L	D	Wt.
STY-N1.7NWST	2.9	1.7	70.0	5.0	—

Tools



- ⊕ Pin key, dual
- ⊕ Material: Steel
- ⊕ One angled end and one straight end

Order Number	ds	d1	L	D	Wt.
STY-N2.9NWST	2.9	2.9	70.0	5.0	—

Tools

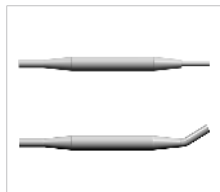

- ⊕ Pin key set
- ⊕ Material: Steel
- ⊕ 1 each: straight and angled pin

Order Number	Description
STY-N1.7-2.9NWST	1 each: straight and angled pin

SOLUTIONS®
"How it works"

Tighten gently and properly with a set of tools and extend the life of your components.



© 2008 Paul W. Marino Gages, Inc.

Phone (586) 759-2400
www.pmarginc.com

121

Fax: (586) 759-2423
pwminc@covad.net

Tools M5
© 2006 Paul W. Marino Gages, Inc.

M5

Tools



- ⊕ Hex wrench
- ⊕ Steel
- ⊕ Used to tighten set screws

Order Number	ds	L	Wt.
STY-HW0.7	0.7	33.0	—
STY-HW0.8	0.8	69.0	—
STY-HW0.9	0.9	39.0	—
STY-HW1.25	1.25	92.0	—
STY-HW1.5	1.5	45.0	—
STY-HW2.0	2.0	51.0	—
STY-HW2.5	2.5	56.0	—
STY-HW3.0	3.0	65.0	—
STY-HW4.0	4.0	70.0	—



Tools and Screws
©2006 Paul W. Marino Gages, Inc.

Screws, Type "A", for Cubes

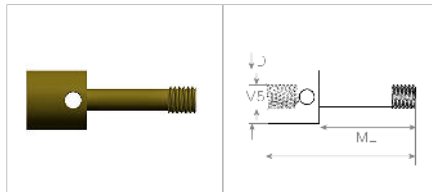

- ⊕ Alu 7075
- ⊕ Used with cubes shown on pages 114-115 and M5 styli

Order Number	ds	L	ML	D	Wt.
STY-N5-20NSWA	M5	31.0	20.0	11.0	3.0
STY-N5-25NSWA	M5	36.0	25.0	11.0	3.0

Screws, Type "B", for Cubes

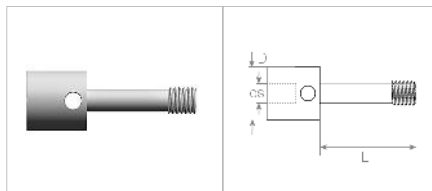

- ⊕ Stainless Steel
- ⊕ Used with cubes shown on pages 114-115

Order Number	ds	L	D	Wt.
STY-N5-20NSWB	4.0	20.0	—	3.0
STY-N5-25NSWB	4.0	25.0	—	4.0

Screws, Type "B", for Discs and Cubes M5

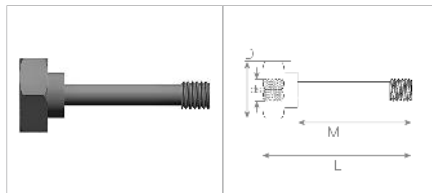

- ⊕ Stainless Steel
- ⊕ Used with Type A discs on page 107 and M5 cubes on pages 114-115

Order Number	ds	L	ML	D	Wt.
STY-N5-15.5NST	M5	15.5	8.0	8.0	7.0
STY-N5-30NST	M5	30.0	21.0	8.0	9.0
STY-N5-35NST	M5	35.0	26.0	8.0	9.0

Screws, Type "L"

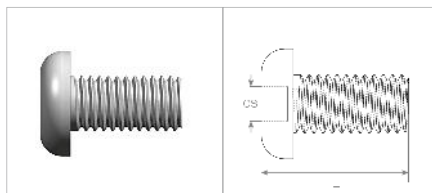

- ⊕ Stainless Steel
- ⊕ Used with Type G discs on page 107

Order Number	ds	L	Wt.
STY-N5-10NSL	3.0	10.0	2.0
STY-N5-12NSL	3.0	12.0	2.0

M5

Screws
© 2006 Paul W. Marino Gages, Inc.

SOLUTIONS® "How it works"

Create custom star and disc assemblies using any combination of styli and accessories in this catalog.

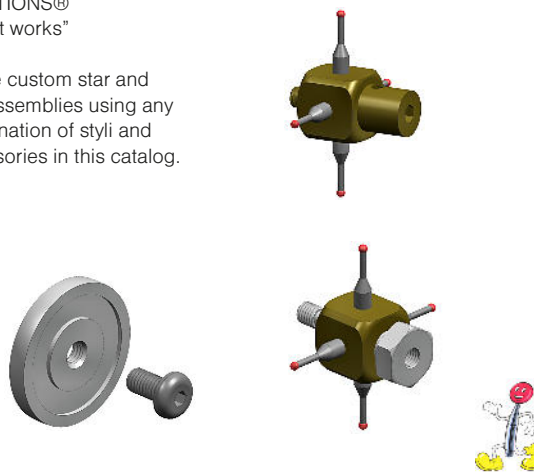

© 2008 Paul W. Marino Gages, Inc.

M5

M5 Stylus Kit, 30 pieces

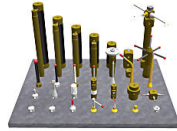

- ⊕ Kit features our most requested styli and accessories
- ⊕ Kit contents: 11 ruby styli, 7 extensions, 7 adapters, 4 screws, 1 tool set and 1 stand

PWM Order Number: STY-N30-11NTA, 30 piece stylus kit with stand

Contents	Qty	Description
STY-N3.0-33.5-11NTB	4	Stylus 3.0 x 33.5 mm M5
STY-N3.0-58-11NTB	2	Stylus 3.0 x 58 mm M5
STY-N5.0-53-11NTB	1	Stylus 5.0 x 53 mm M5
STY-N8.0-63.5-11NTB	1	Stylus 8.0 x 63.5 mm M5
STY-N8.0-114.5-11NTKE	1	Stylus 8.0 x 114.5 mm M5
STY-N2.0-55-11NTF	1	Stylus 2.0 x 55 mm M5
STY-N1.5-26.5-11NTN	1	Stylus 1.5 x 26.5 mm Pin
STY-N40-11NVPE	2	Extension 40 mm Alu7075
STY-N60-11NVPE	2	Extension 60 mm Alu7075
STY-N100-11NVPE	1	Extension 100 mm Alu7075
STY-N120-11NVPE	2	Extension 120 mm Alu7075
STY-N1.0-10-11NHT	1	Holder for 1.0 mm pin styli
STY-N25-11NDSP	1	Adapter, rotary
STY-N15-15NWA	2	Cube 15 mm
STY-N15-15NWB	2	Cube 15 mm
STY-N30-11NGA	1	Knuckle
STY-N5-20NSWA	2	Screw
STY-N5-20NSWB	2	Screw
STY-N1.7-2.9NWST	1	Tool set
STY-PLATE-M5	1	Stand for M5 accessories

M5 Stylus Kit
 ©2008 Paul W. Marino Gages, Inc.

